

¶Included w/Wheel Bearing Kit

Housing, Strut-See Front Suspension Section

4 Caliper, Brake	R	441 615 108	m #5	795.00
	L	441 615 107	m #5	795.00
5 Carrier, Caliper	R	441 615 306	m #5	23.00
	L	441 615 305	m #5	23.75

#R&R One Side Complete, R&R Both Sides .8, w/Rotor Removed .3

6 Shield, Splash	R	441 615 312 D	m #2	33.70
	L	441 615 311 D	m #2	32.75

¶Order by Application

#w/Rotor & Hub Removed

Sensor, ABS	R/L	441 927 803 D	m #5	154.00
-------------	-----	---------------	------	--------

#R&R Both .8

Bracket, Sensor	R/L	811 971 848 E	m	1.10
Hose, Brake	R/L	443 611 707 C	m #3	72.30

#w/Caliper Removed .2

4 WD ARM & STRUT

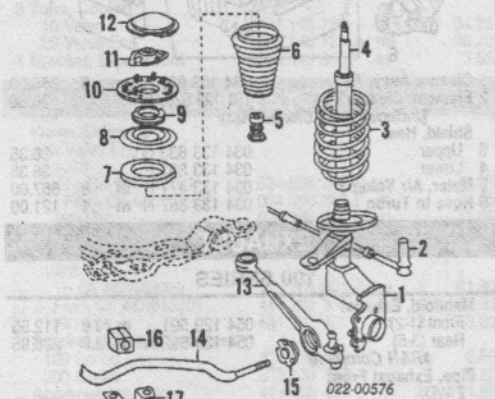

1 Housing, Strut	100 Series w/ABS	R	443 412 024 K	m #3.2	489.20
		L	443 412 023 K	m #3.2	489.20
	w/o ABS	R	443 412 026 K	m #3.2	489.20
		L	443 412 025 K	m #3.2	489.20
	200 Series				
	10 Valve Eng	R	443 412 024 K	m #3.2	489.20
		L	443 412 023 K	m #3.2	489.20
	20 Valve Eng	R	441 412 026 D	m #3.2	489.20
		L	441 412 025 D	m #3.2	489.20

2 Sensor, ABS Wheel-See Rotor & Hub Section	R/L	431 411 105 S	952 m #3.2	195.30
---	-----	---------------	------------	--------

¶Order by Application

4 Absorber, Shock	10 Valve Eng	R/L	443 413 031 F	m #3.2	110.85
	20 Valve Eng	R/L	441 413 031 G	m #3.2	159.15
5 Pad, Stop	100 Series	R/L	443 412 131 A	m #3.2	4.95
	200 Series				
	10 Valve Eng	R/L	443 412 131 B	m #3.2	4.95
	Sedan	R/L	445 412 131	m #3.2	27.35
	Wagon	R/L	445 412 131	m #3.2	27.35
	20 Valve Eng	R/L	431 412 175 D	m #3.2	10.55

#R&R One Side Complete

7 Ring, Damping	R/L	441 411 109	m #3.2	9.55
8 Seat, Spring Upper	R/L	441 412 111	m #3.2	26.95

9 Bearing	10 Valve Eng	R/L	441 412 249 A	m #3.2	28.60
	20 Valve Eng	R/L	441 412 249 A	m #3.2	28.60
10 Support, Spring	10 Valve Eng	R/L	443 412 321	m #3.2	48.65
	20 Valve Eng	R/L	441 412 321 A	m #3.2	74.45

11 Mounting, Strut	10 Valve Eng	R/L	443 412 377	m #3.2	27.50
	20 Valve Eng	R/L	441 412 377 D	m #3.2	112.85
12 Cap, Protective	R/L	441 412 375	m #3.2	3.65	

#R&R One Side Complete, Both Sides 6.0

13 Arm Assy, Track	10 Valve Eng	R	437 407 152 A	m #1.8	274.65
		L	437 407 151 A	m #1.8	274.65
	20 Valve Eng	R	441 407 152 A	m #1.8	287.45
		L	441 407 151 A	m #1.8	287.45

Bushing, Track Arm	Inner	R/L	431 407 183 A	m #1.8	28.65
--------------------	-------	-----	---------------	--------	-------

¶Included w/Track Arm Assy

#R&R Complete, Includes R&R Stabilizer, Arm & Bushing, Not Included in O/H

14 Bar, Stabilizer	10 Valve Eng	447 411 309	m #9	251.75
	20 Valve Eng	441 411 309 F	m #9	251.75

#Not Included in O/H

15 Bushing, Bar Outer (2)	R/L	431 407 181 F	m #3	17.95
16 Bushing, Bar Inner	R/L	447 411 327 B	m #3	8.35

#w/Bar Removed, Not Included in O/H

17 Bracket, Bar Inner	1989				
	To Ch 44K084000	R/L	447 411 336	m #1.2	3.45
	From Ch 44K084001	R/L	441 411 336 B	m #1.2	8.60
	1990-91	R/L	441 411 336 B	m #1.2	8.60

#R&R Complete, Not Included in O/H

FRONT DRIVE AXLE

R&I Axle Shaft Assy				
Man Trans		R/Lm	#1.3	
Auto Trans		R/Lm	#1.8	

#w/Strut Housing Removed Deduct 1.0

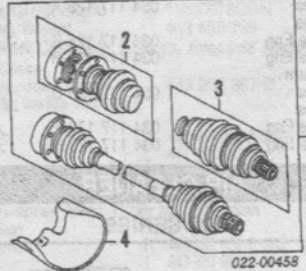

1 Shaft Assy, Axle	100 Series w/ABS			
	Man Trans	R	443 407 272 AKm	#1.3 535.00
		L	443 407 271 ATm	#1.3 535.00
	Auto Trans	R	443 407 272 BDM	#1.8 535.00
		L	443 407 271 BNm	#1.8 535.00
	w/o ABS	R	431 407 272 L	m #1.3 d535.00
		L	431 407 276 G	m #1.3 535.00
	200 Series			
	Man Trans	R/L	447 407 271 F	m #1.3 680.00
		R	447 407 272 H	m #1.8 680.00
		L	447 407 271 K	m #1.8 680.00

#w/Strut Housing Removed Deduct 1.0

2 Joint, CV Inner	R/L	431 498 103 C	m #7	175.95
-------------------	-----	---------------	------	--------

¶Included w/Axle Shaft Assy

3 Shaft w/Join, Outer	100 Series w/ABS			
	Man Trans	R/L	443 498 099 BXm	#1.1 247.20
		R/L	443 498 099 EXm	#1.1 247.20
		R/L	443 498 099 AXm	#1.1 247.95
	w/o ABS			
	200 Series			
	Man Trans	R/L	447 498 099	m #1.1 462.85
		R/L	443 498 099 GXm	#1.1 247.20

¶Included w/Axle Shaft Assy

#w/Axle Shaft Assy Removed

4 Shield, Right Side	2 WD	443 407 722	m	22.25
	4 WD	443 407 719	m	12.65

FRONT STEERING LINKAGE/GEAR

NOTE: R&R Does Not include adjust wheel alignment.

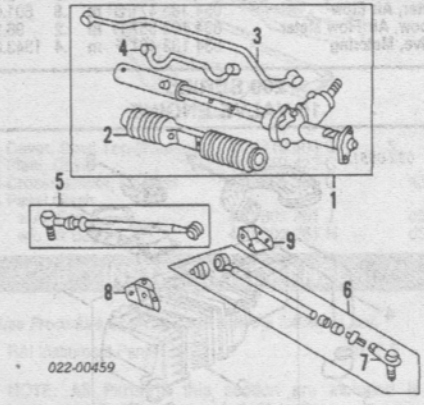

1 Gear Assy	443 422 065 LX	m 2.8	750.00
2 Boot	431 419 831	m #3.0	46.60

#Includes R&I Gear Assy

3 Pipe, Feed	443 422 251 A	m	35.40
4 Left	443 422 251	m	35.40

¶Included w/Gear Assy

5 Rod Assy, Tie	443 419 802 E	m .7	163.90
6 Left	443 419 801 E	m .7	163.90
7 End, Tie Rod	R	443 419 812 D	m .4 73.65
	L	443 419 811 D	m .4 75.80

¶Included w/Tie Rod Assy

8 Coupling, Tie Rod	431 419 853	m	2.70
9 Bracket, Coupling	443 419 313	m	29.65

STEERING PUMP

Illustration Located in Next Column

Pump Assy	100 Series	034 145 155 DXm	1.8	383.60
	200 Series	034 145 155 C	m 1.8	d762.00

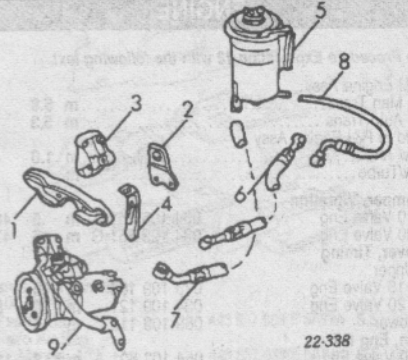

Pulley, Pump	035 145 255 G	m 1.0	19.05
Belt, Drive	068 260 849	.7	10.25
1 Bracket, Pump Front	035 145 523 C	m	11.95
2 Bracket, Pump Rear	035 145 525 B	m	63.50
3 Bracket, (To Block)	035 145 515 B	m	53.05
4 Brace, Adjust	035 145 545 F	m	8.85
5 Reservoir	443 422 371 F	m 1.0	127.70
Bracket, Reservoir			
10 Valve Eng	443 422 845	m	48.20
20 Valve Eng	447 422 845	m	d48.20
6 Hose, Gear Pressure	443 498 892 C	m .7	177.50
7 Hose, Suction			
100 Series			
1989			
To Ch 44K035000	447 422 887 A	m .7	57.60
From Ch 44K035001	447 422 887 C	m .7	57.60
1990-91	447 422 887 C	m .7	57.60
200 Series	447 422 887 A	m .7	57.60
8 Hose, Return			
100 Series	443 422 891 B	m .7	61.60
200 Series	443 422 891	m .7	61.60
9 Pipe, Pump			
To Brake Press Accumulator	443 612 059 J	m	149.05

STEERING WHEEL/COLUMN

R&I Steering Column	m 1.5
O/H Steering Column (Includes R&I)	m 3.0

NOTE: All Parts in this section are included in overhaul unless noted otherwise.

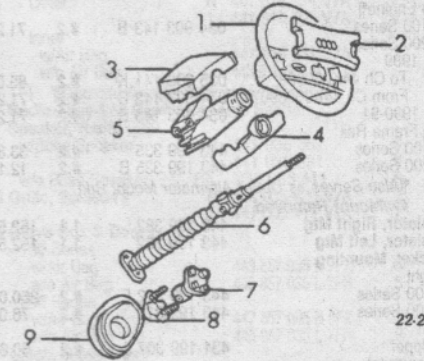

1 Wheel, Steering	w/Air Bag	4A0 419 091 E	9AV m .3	703.00
	w/o Air Bag			
	Leather	893 419 091 G	5VN m .3	d214.00
	Vinyl	893 419 091 E	01Cm .3	d118.85
	8A0 951 525 A	01Cm	2	100.10

2 Pad, Horn	Module, Air Bag-See Air Bag System Section			
3 Cover, Lock Housing Upper	w/Air Bag	441 953 515 A	7FRm #6	46.90
	w/o Air Bag	443 953 515 D	V7Am #6	45.70

4 Cover, Lock Hsg Lower	w/Air Bag	441 951 593 C	7FRm #6	84.50
	w/o Air Bag	443 951 593 B	V7Am #6	45.05

#R&R Complete

Switch, Directional	443 953 513 K	01Cm .7	160.85
---------------------	---------------	---------	--------

Switch, Wiper/Washer

w/On Board Computer	445 953 503 F	01Cm .6	185.05
w/o On Board Computer	445 953 503 E	01Cm .6	103.40

Housing Assy, Lock

441 905 851	m 1.2	72.40	
Switch, Ignition	4A0 905 849 B	m .7	28.50

¶Included w/Lock Housing Assy

Cylinder & Key, Lock	893 905 855 A	m #1.8	66.85
----------------------	---------------	--------	-------

#Does Not Include Recode

5 Jacket, Column	w/Air Bag	441 419 561 A	m 2.7	193.85
	w/o Air Bag			
	1989-91			
	To Ch 44L054000	8G1 419 561 D	m 2.7	177.95
	From Ch 44L054001	8G1 419 561 D	m 2.7	177.95

6 Shaft, Steering Upper	893 419 509	m 2.6	302.45
7 Shaft, Steering Lower	893 419 761 A	m .7	112.40
8 Joint, Lower Flange	893 419 536 C	m	9.95
9 Boot, Lower Flange	443 419 523	m	28.20